

KOMATSU

AE50/AM50 Series

1.0-2.0ton Electric Trucks



www.Komatsu.com

Printed in Japan 0711-5-03TP

KOMATSU[®]

Form No.BR-AEAM50-004

Materials and specifications are subject to change without notice
KOMATSU is a trademark of Komatsu Ltd. Japan

Best Solution for All Scenes

Komatsu's electric counter balanced trucks bring bold improvements—reduction of total operating cost, high productivity resulting from outstanding performance that nears that of internal combustion engine trucks, great operator safety and comfort. Komatsu AE50/AM50 Series offers excellent ideas and features out of the diligent commitment to fulfill the customer needs. Either engine or electric, the AE50/AM50 Series has the answer to the most efficient cost reduction in material handling industry.

Models

AE50 Series/4-wheel Type

Standard Truck

1.0t/1.35t/1.5t/1.75t/2.0t Compact Truck

Large Capacity Battery Truck

1.5t/1.75t/2.0t Compact Truck

AM50 Series/3-wheel Type

1.0t/1.25t/1.5t/1.75t/2.0t



Low Total Operating Cost by Sophisticated Komatsu Design

The AE50/AM50 Series features Komatsu's original Total AC system and the special airtight wet disc brake system that efficiently reduce the maintenance costs. Komatsu furthermore offers exceptional water resistance technology and high reliability. Unlike the engine trucks, there is no need for the engine-related periodical maintenance changes. The AE50/AM50 Series goes above and beyond in keeping the operating costs at the lowest.

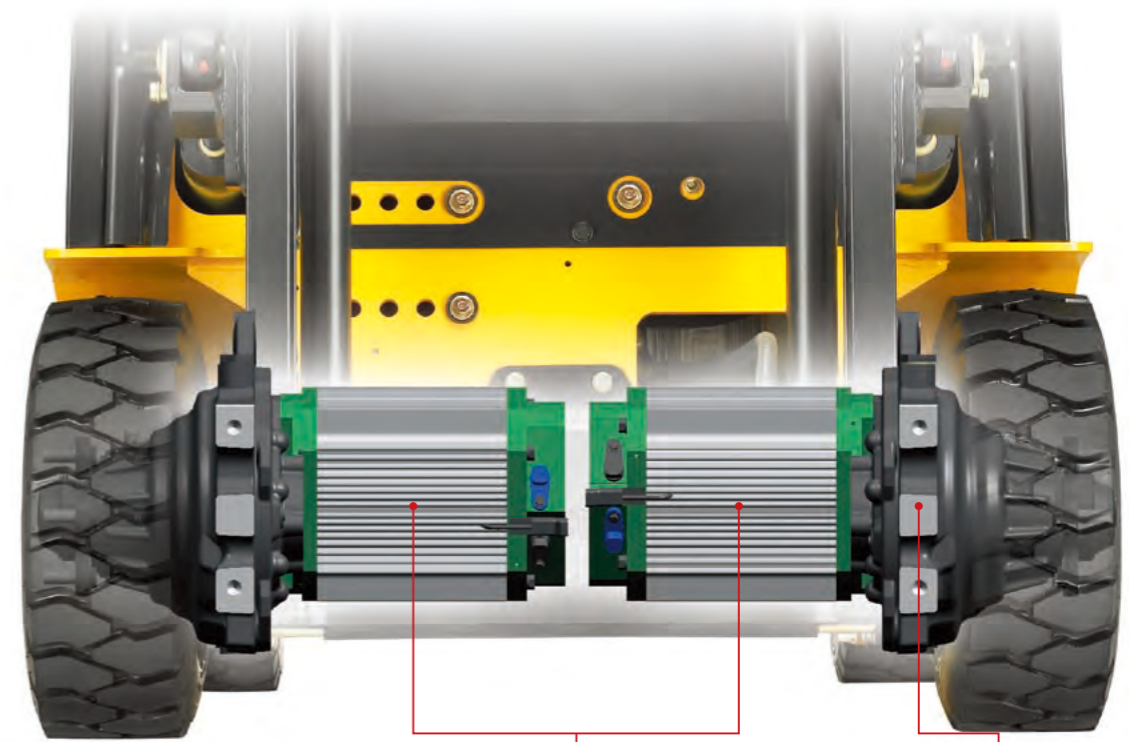

Minimum Maintenance Cost with the Total AC System

Along with the 2 traveling motors, the AE50/AM50 Series also utilizes advanced AC motors for hydraulic operation. Since it completely eliminates the need for motor brush or contractor replacements, the maintenance costs are further reduced. Moreover, not only does AC motor have a high operating efficiency, but it also has a long operating life. The power saving function enables the trucks to operate for a long period without having low output.

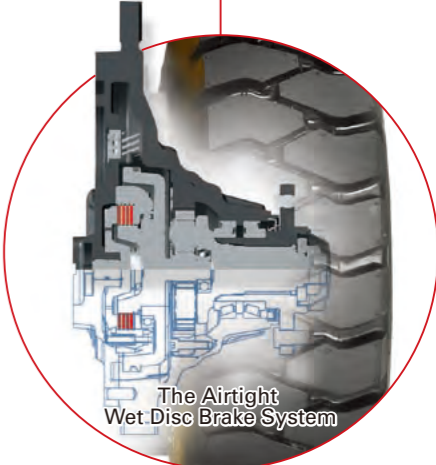

Exceptional Durability with the Airtight Wet Disc Brake System

The airtight wet disc brake system efficiently ensures exceptional overall durability. Unlike the conventional drum brake systems, this system requires no extensive periodical maintenance except for oil changes, therefore reducing the maintenance costs.

IP X4* Waterproof Standard Specification

Komatsu AE50/AM50 Series meets the IPX4 waterproof standard with the meticulous considerations in its proportional hydraulic control valves, control micro-switches, potentiometers as well as control signal circuits. With the reliable waterproof design, the trucks can easily be washed with running water.

*IP: International Protection

Superior Reliability

By making the controller system lighter, more simple and compact than ever, Komatsu consistently seeks for the best design to eliminate possible troubles. We conduct a series of thorough tests for water resistance and circuit reliability in order to ensure the highest standard. The controller is stored within tightly closed containers. Komatsu also places a strong emphasis on designing the controller system layout that keeps the water and dust out from the important parts of the truck.

Excellent Maintenance Characteristics

The AE50/AM50 Series adopts the dumper-assisted battery hood, which makes the battery checkups smoother and easier. Moreover, the Komatsu's original self-diagnostic system run by standard personal computers greatly facilitates the problem solving process, minimizing the down time.



Outstanding Performance Ensuring High Productivity

All-around Dual Drive loaded with the AC 2 motors ensures the powerful traveling ability. The AE50/AM50 Series offers agile turning performance by incorporating a high-mounted rear axle and adopting original low-mounted battery that keeps the trucks' center of gravity low. The new series also offers a wide battery range and the side battery access that allow the trucks to be utilized for long continuous operations. With these exceptional features, the AE50/AM50 Series guarantees excellent performance that even nears that of engine trucks





Superb Traveling Performance Offered by All-around Dual Drive

All-around Dual Drive, in which each of the two front wheels is driven by an AC motor, confers the powerful traveling performance comparable to that of engine trucks. Indeed, Komatsu's All-around Dual Drive ensures excellent traveling performance even under the most undesirable floor/ground conditions.

Maximum traveling speed 17.0km/h (FB15/unloaded)	Acceleration (Acceleration time from 0 to 5 m) 2.9seconds (FB15/unloaded)	Gradeability 15.6degrees (FB15/unloaded)
---	---	---

* All data are measured with the traveling power set at H.

Stable Control by the Airtight Wet Disc Brake System

Not only does this Komatsu brake technology confer excellent control even under wet floor conditions, it also offers smooth braking applications that further enhances productivity.



Superb Turning Stability

Komatsu design technology achieves excellent turning stability even during high speed turns thanks to high-mounted rear axle and low-mounted battery that ensure the low center of gravity. Rubber mount rear axle absorbs shocks and vibrations for great riding comfort.



Advanced Controller

The AE50/AM50 Series features the advanced controller, which regulates all required functions, as well as the safety mechanisms such as traveling/lifting Operator Presence Sensing. Moreover, the power saving function guarantees the AC motor's best performance even at higher battery discharging stage.



Side Battery Access

The AE50/AM50 Series makes the battery exchange safer and smoother, making it ideal for continuous operations 24 hours a day, 7 days a week.



Proportional Hydraulic Control Valve

The amount of oil is accurately controlled by the reliable computing system. By providing feathering smooth control and minimizing the shocks during fork movement, the AE50/AM50 Series is ideal for handling sensitive and fragile materials.

Fully Hydrostatic Power Steering (FHPS) System

Komatsu's hydrostatic power steering system allows smooth and easy stationary steering and switchbacks, providing outstanding agility and comfort. With a smaller 300mm-diameter steering wheel, Komatsu AE50/AM50 Series has attained superior responsiveness, optimizing maneuverability even in narrow spaces. The fluctuations during straight traveling are also minimized, further enhancing the travel stability. Moreover, this steering system automatically detects undesirable knob slides and restores back to its original position.



- Easy and smooth stationary steering and switchbacks
- Significant fluctuation reduction during straight traveling
- Steering Synchronizer Function



Diligent Pursuit of Safety and Comfort

Ensuring operator's safety and comfort is essential in reducing the total operating costs and therefore also in achieving high productivity and efficiency.

The AE50/AM50 Series features new hydraulic operation and traveling control levers, function setups, as well as ideal ergonomic layout of the operation devices.

Safety devices such as traveling/lifting Operator Presence Sensing system are installed in order to ensure safety of the operators at all times.

Ergonomic Combination Lever

The combination lever is Komatsu's original invention based on advanced ergonomic knowledge. This lever optimizes operating processes by cutting down unnecessary movements: operators can smoothly and effortlessly maneuver lifting and tilting levers, and shift the travel direction just by a light touch to the switch on the lifting lever. Moreover, operators can easily maneuver the truck in an ideal seating posture, ensuring comfort even during a long continuous operation.



Traveling/lifting Operator Presence Sensing System

The traveling/lifting Operator Presence Sensing System is a safety function which meets ISO3691. This safety system allows hydraulic or traveling operations only when the operator is seated. Specifically the alarm is activated and operation stops three seconds after the operator leaves the seat without applying parking brake. The Operator Presence Sensing System is a double safety measure and remains activated even when the operator returns to the seat. The interlock can only be released by returning the respective switch to a safe position.

*The interlock function stops the traveling operations for safety during undesirable conditions, and it does not forcibly control the truck.

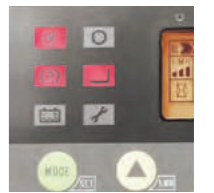

The interlock state is also indicated on the meter panel.

Adjustable Individual Setups

Functions such as traveling, lifting and tilting speeds can be adjusted according to a variety of individual needs. These adjustments can easily be made with simple steps on a meter panel at any time. With adjustable setups, operations can individually be optimized, making operations smoother and more comfortable.



- Traveling Speed Setup
- Lifting Speed Adjustment
- Plugging Regeneration Setup
- Tilting Speed Adjustment
- Accelerator Neutral Regeneration Setup

Comfortable Access to the Truck

The step and floor of the AE50/AM50 Series trucks are kept low and spacious in order to minimize the operator burden during entry and exit. The access to the truck is further facilitated by the considerate design around the steering and assisting grip. Operators can easily walk through the truck to the opposite side.



HSS II Seat

Komatsu's original cushioning and dumper technology efficiently absorbs vibrations. Furthermore, the HSS II seat is specially designed to support the entire body in order to minimize fatigue even in long continuous operating sessions.

Hip-supporting & Seat-belt System



- 6-step backrest adjustment
- Cushioning adjustable to operator body weight
- 170-mm forward/backward sliding
- Retractable seat belt

Excellent Visibility

The AE50/AM50 Series offers excellent visibility in all direction for safety. In order to minimize the front dead angles, the operating seat is located to the left side of the truck. Moreover, Komatsu utilizes the high-visibility masts and places meter panel on top of the dashboard in order to secure clear front view, allowing operators to clearly see the tips of the forks.



Paper Binder

The AE50/AM50 Series is equipped with a convenient large-size paper binder beside the operator seat. The paper binder also has a space for items such as pens and pencils.



High-mount Rear Combination Lamp

Turning signals, backup lamps and stop lamps are all located together on top of the rear overhead guard to optimize the truck visibility for safer operations.

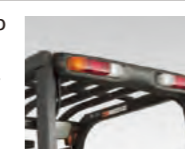

Wide-angle Center Mirror

The wide-angle center mirror provides a wide rear view area for safer operations.



Three-wheel Trucks with Pivot Turn Ability / AM50 Series

The AM50 Series features three-wheel trucks with a rear wheel that can be turned 90°. Furthermore, the forced inner wheel reverse function exclusively makes the front inner tyres rotate in the opposite direction when the rear wheel is turned more than 75°. This features powerful driving force for smoother sharp turns as well as pivot turns.

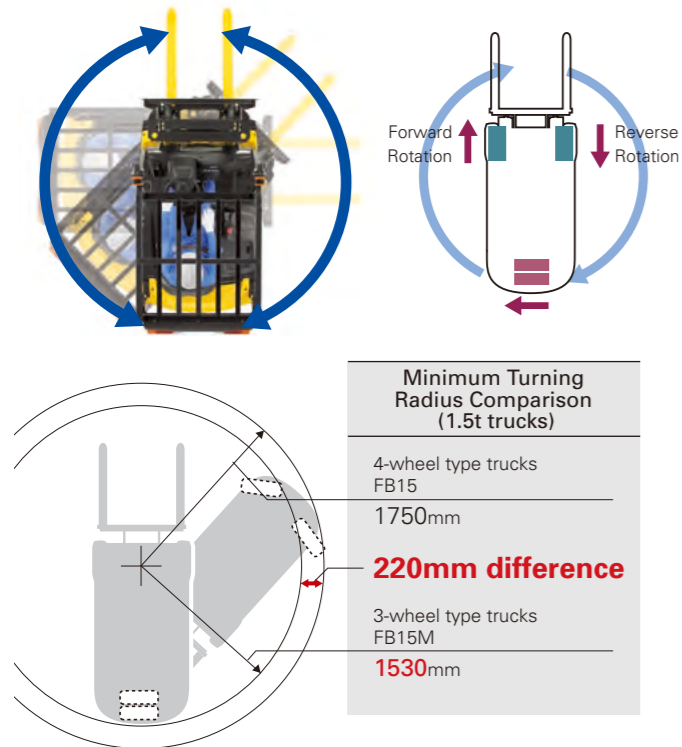

Improved Maneuverability—2.0t Compact Trucks

Komatsu proudly offers original 2.0 t compact 4-wheel and 3-wheel trucks. The minimum turning radius for 2.0 t compact trucks is 1,850 mm, conferring exceptional agility for smoother traveling in narrow spaces.

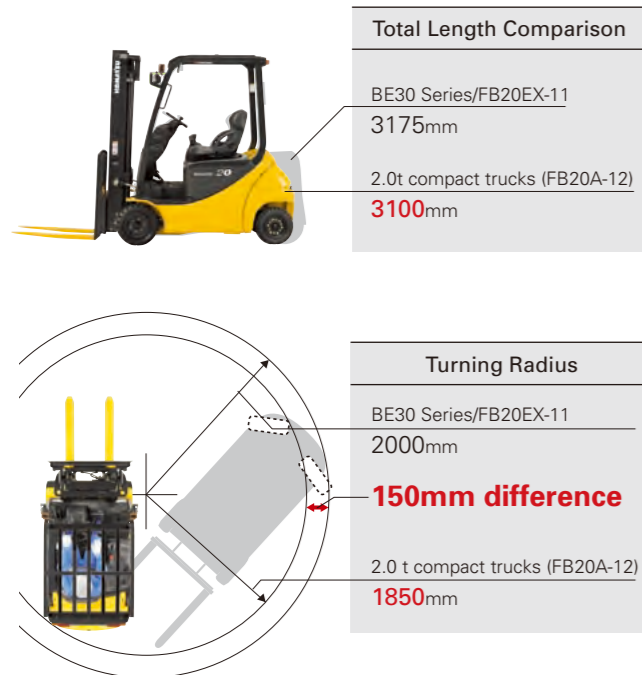

Substantial Options

Digital Load Checker

Approximate loads are measured and digitally displayed in 10kg unit.



Laser Lift Height Sensor

This indicates the height of the fork with a laser beam, making the fork insertion to palettes easier and smoother.

Safety Rearview Mirrors/Left and Right

Komatsu AE50/AM50 Series are equipped with the left and right rearview mirrors in addition to the standard center rearview mirror in order to assure safety during performance.

Softcarry (Hydraulic Accumulator System)

The shock reduction system absorbs the travel vibrations and therefore protecting handling cargos. This system also efficiently reduce the vibrations of the forks during hydraulic operations. This system is especially suitable for operations in rough floor surface conditions as well as for handling fragile and expensive cargos such as precision machines and electronic parts.



Protective Resin Head Guard Cover

With this protective head guard cover, the trucks can be used even out in the rain.



Wide Battery Range

Even for the standard 1.0 t specification truck, large 565Ah battery can be selected from the wide range of battery. Komatsu also offers high battery capacity trucks that can load 725Ah battery perfect for long continuous operations.

Battery Capacity (Ah/5HR)	AE50 Series/4-wheel							AM50 Series/3-wheel					
	10	14	15	18	20A	15G	18G	20AG	10M	13M	15M	18M	20M
330	●	●	●	●	●								
402	●	●	●	●	●						●	●	
468	●	●	●	●	●						●	●	●
565	●	●	●	●	●						●	●	●
280									●	●			
312									●	●			
370									●	●			
645							●	●	●				
725							●	●	●				

●: Available

Safety Support Equipment

- Forward/Back-up Chime
- Strobe Light (yellow/red/blue)
- Rear Working Light
- Fire Extinguisher (with Headguard)

Exterior

- Seat Heater
- Windshield Wiper (with window washer)

Supportive Equipment for Hydraulic Operation

- Automatic Fork Leveling Device
- Automatic Lifting Stop Function

Battery Charger-related

- Easy Open Side Battery Access Door
- Battery with Easy Water Supply Apparatus



Optional Specification Truck

Cold Storage Specification (-35°C)

The truck's outstanding anticorrosive coatings and durability make it a reliable workhorse even in a rigorous working conditions

Fishery Specification

Komatsu's finest anticorrosive and durability technology makes the trucks possible to be used even under harsh conditions that impose frequent contact with salt and water

Dustproof (electric-tight) Specification

All major electronic parts are tightly enclosed to keep the dusts out. This truck is perfect for operations under dusty conditions

Attachment

- Integral side shifter



- Fork positioner
- Roll clamp
- Hinged fork
- Rotating fork
- Load stabilizer
- Fork clamp
- Bale clamp

Mast

2-stage Free View Mast

(maximum fork height: 2700-5000mm)
Mast featuring wide front view between the inner masts

Full Free View Mast

(maximum fork height: 3000-4000mm)
Mast with extremely large free lift, especially suitable for the application that limits mast rise

3-stage Full Free View Mast

(maximum fork height: 3700-6000mm)
Mast with large free lift with higher maximum fork height, especially suitable for operations to lift loads to high rack

Major Equipment

● : Standard ○ : Option △ : Available upon Request - : N/A S : Adjustable by service mechanic

		AE50 Series/4-wheel		AM50 Series/3-wheel
		Standard Truck	Large Capacity Battery Truck	Standard Truck
		1.0~2.0t	1.5~2.0t	1.0~2.0t
ICS (Intelligent Computer Control System)		●	●	●
Motors	Traveling Motor	AC	AC	AC
	Hydraulic and Steering Motor	AC	AC	AC
All-around Dual Drive		●	●	●
Airtight Wet Disc Brake		●	●	●
Proportional Hydraulic Control Valve		●	●	●
Combination Lever (Forward/Reverse switch integrated)		●	●	●
Steering Type		FHPS	FHPS	FHPS
Setup	Traveling Property Adjustment	Traveling Speed Property	●	●
		Plugging Regeneration Property	●(S)	●(S)
		Brake Regeneration Property	●(S)	●(S)
		Soft-start Property	●(S)	●(S)
		Accelerator Property	●(S)	●(S)
		Accelerator Neutral Regeneration Property	●(S)	●(S)
		Slope Regeneration	●(S)	●(S)
	Hydraulic Operation Property Adjustment	Traveling Speed Control	●	●
		Lifting Speed Adjustment	●	●
		Tilting Speed Adjustment	●(S)	●(S)
Regeneration	Attachment Speed	●(S)	●(S)	
	Plugging Regeneration	●	●	
IMS (Intelligent Monitoring System)	Brake Regeneration	●	●	
	Accelerator Neutral Regeneration	●	●	
	Speedometer	●	●	
	Forward/Reverse Indicator	●	●	
	Speed Limit Indicator	●	●	
	Calendar/ Service meter	●	●	
	Traveling Power Indicator	●	●	
	Battery Discharge Indicator	●	●	
	Fork Leveling Indicator	○	○	
	Load Checker(10kg unit)	○	○	
Operation Equipment Related	Parking Brake Indicator	●	●	
	Neutral Start Indicator	●	●	
	Travel Interlock Warning Lamp	●	●	
	Lift Interlock Warning Lamp	●	●	
	Failure Indicator	●	●	
	Electrolyte Level Indicator	●	●	
	Telescopic-tiltable Steering Column	●	●	
	Auto-return Turning Signal Lever	●	●	
	Soft-landing Device	●	●	
	Operator Presence Sensing System (Lifting/Traveling Interlocking Mechanism)	●	●	
Safety Support Equipment	Emergency Switch	●	●	
	Neutral Start	●	●	
	Automatic Power Off	●	●	
	Anti Roll-back	●	●	
	Traveling Speed Control	●	●	
	Key-off Lift Lock	●	●	
	Parking Brake with release button	●	●	
	Back-up Buzzer	●	●	
	Load Checker	○	○	
	Forward/Back-up Chime	○	○	
Supportive Equipment for Hydraulic Operation	Rear View Mirror (Left & Right)	○	○	
	Wide-angle Center Mirror	●	●	
	Rear Working Light	○	○	
	Strobe Light (yellow/red/blue)	○	○	
	Fire Extinguisher	○	○	
	Automatic Fork Leveling Device	○	○	
	Laser Lift Height Sensor	○	○	
	Automatic Lifting Stop Function	△	△	
	Softcarry (Hydraulic Accumulator)	○	○	
	Floor Mat	●	●	
Exterior	HSS II Seat (with seat belt)	●	●	
	Steel Cabin	△	△	
	Windshield Wiper (with window washer)	○	○	
	Protective Resin Head Guard Cover	○	○	
Others	Seat Heater	○	○	
	Pen Tray	●	●	
Battery Related	Paper Binder	●	●	
	Side Battery Access	●	●	
	Easy Open Side Battery Access Door	○	○	
	Battery with Easy Water Supply Apparatus	○	○	

Load capacity curve 2-stage Free View Mast

AE50 Series/Standard Truck

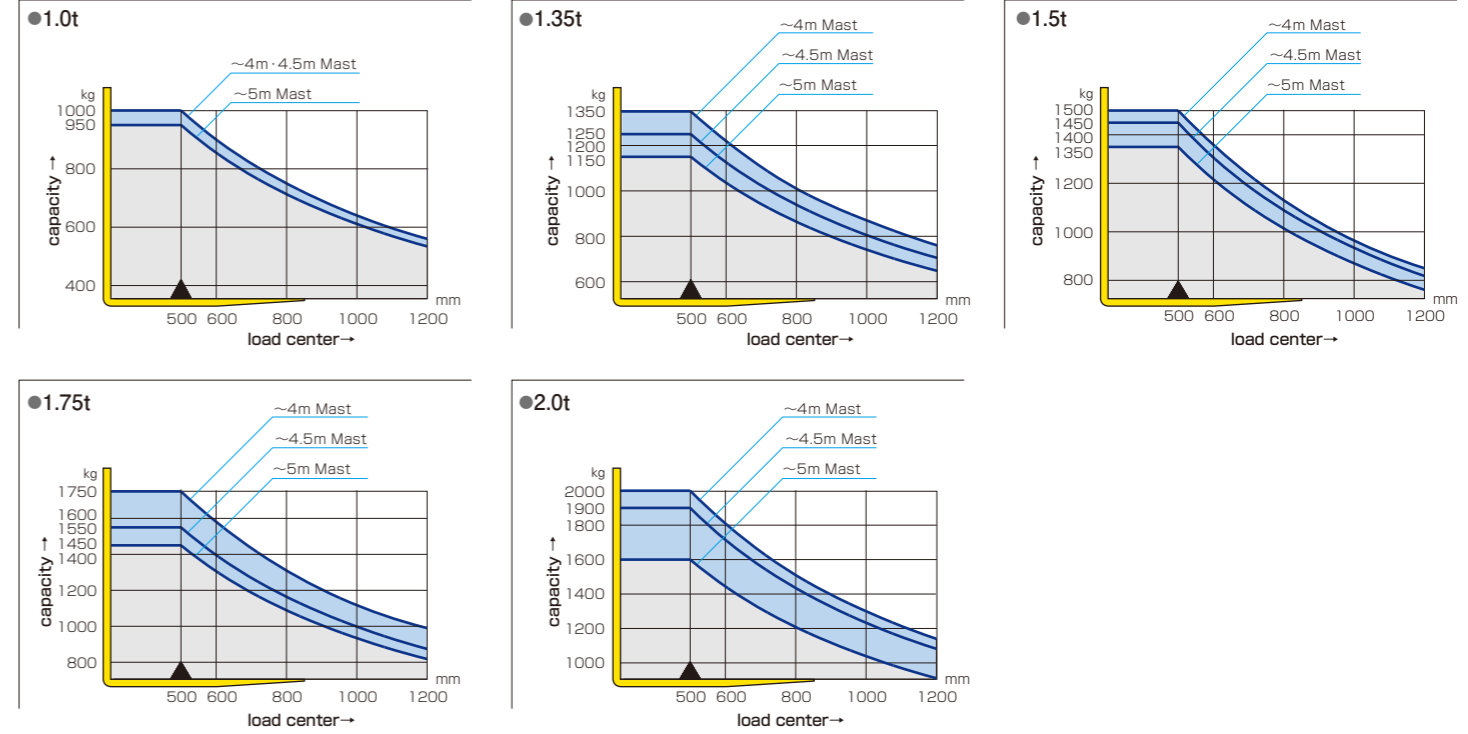

AE50 Series/Large Capacity Battery Truck

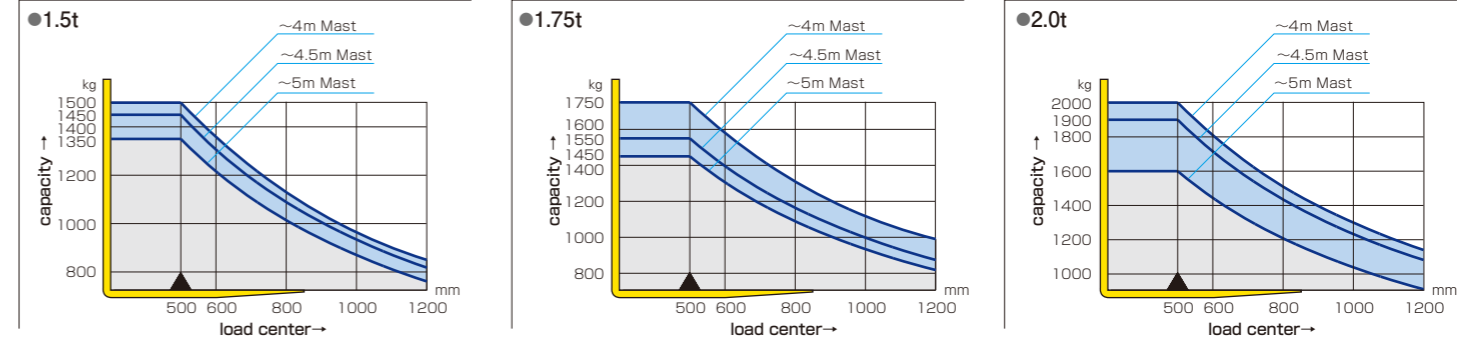

AM50 Series

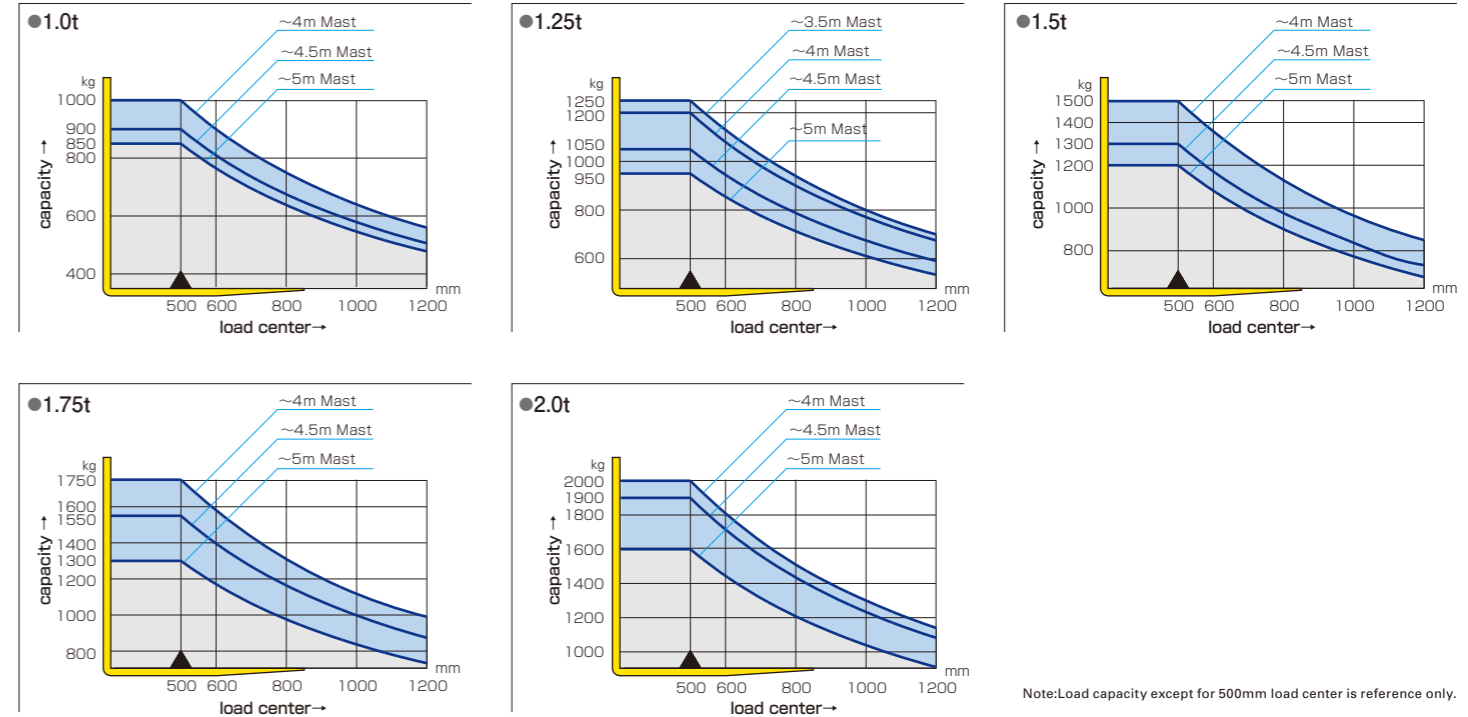

Note: Load capacity except for 500mm load center is reference only.

AE50/AM50 Series Specifications

				FB10-12	FB14-12	FB15-12	FB18-12	FB20A-12	FB15G-12	FB18G-12	FB20AG-12	FB10M-12	FB13M-12	FB15M-12	FB18M-12	FB20M-12		
Characteristics	1.2	Model	Manufacturer's Designation															
	1.3	Power Type	Electric, Diesel, Gasoline, LPG, Cable	Electric	Electric	Electric	Electric	Electric	Electric	Electric	Electric	Electric	Electric	Electric	Electric	Electric		
	1.4	Operation Type		Sitting	Sitting	Sitting	Sitting	Sitting	Sitting	Sitting	Sitting	Sitting	Sitting	Sitting	Sitting	Sitting		
	1.5	Rated Capacity	Q	Rated Capacity	kg	1000	1350	1500	1750	2000	1500	1750	2000	1000	1250	1500	1750	2000
	1.6	Load Center	c	Rated Load Center	mm	500	500	500	500	500	500	500	500	500	500	500	500	500
	1.6.1	Alternative Capacity	Q2	Capacity@600mm Load Center	kg	900	1210	1350	1570	1800	1350	1570	1800	900	1210	1350	1570	1800
	1.8	Load Distance	x	Front Axle Center to Fork Face	mm	400	405	405	405	425	405	405	425	400	400	405	405	425
	1.9	Wheelbase	y		mm	1410	1410	1410	1410	1470	1540	1540	1540	1190	1190	1340	1390	1485
	2.1	Service Weight	Including Min. Capacity Battery, See line 6.5		kg	2770	2790	2930	3170	3620	3360	3390	3730	2600	2710	2980	3260	3730
Weight	2.2	Axle Loading	Loaded	Front	kg	3080	3680	3980	4400	5020	4060	4540	5010	3100	3540	4000	4430	5080
	Rear			kg	690	460	450	520	600	800	650	720	500	420	480	580	650	
	2.3		Unloaded	Front	kg	1410	1440	1490	1490	1720	1680	1680	1810	1310	1310	1460	1510	1790
	2.3.1			Rear	kg	1360	1350	1440	1680	1900	1680	1710	1920	1290	1400	1520	1750	1940
Tyres	3.1	Tyre Type	Cushion, Elastic Cushion, Pneumatic, Polyurethane	Pneumatic	Pneumatic	Pneumatic	Pneumatic	Elastic Cushion	Pneumatic	Pneumatic	Elastic Cushion	Pneumatic	Pneumatic	Pneumatic	Pneumatic	Elastic Cushion		
	3.2	Tyre Size	Front	18x7-8-16PR(I)	18x7-8-16PR(I)	18x7-8-16PR(I)	18x7-8-16PR(I)	200/50-10	18x7-8-16PR(I)	18x7-8-16PR(I)	200/50-10	18x7-8-16PR(I)	18x7-8-16PR(I)	18x7-8-16PR(I)	18x7-8-16PR(I)	200/50-10		
	3.3		Rear	16x6-8-10PR(I)	16x6-8-10PR(I)	16x6-8-10PR(I)	16x6-8-10PR(I)	16x6-8	16x6-8-10PR(I)	16x6-8-10PR(I)	16x6-8	15x4 1/2-8-12PR(I)	15x4 1/2-8-12PR(I)	15x4 1/2-8-12PR(I)	15x4 1/2-8-12PR(I)	15x4 1/2-8		
	3.5	Number of Wheel	Front/Rear (x=driven)	2x/2	2x/2	2x/2	2x/2	2x/2	2x/2	2x/2	2x/2	2x/2	2x/2	2x/2	2x/2	2x/2	2x/2	
	3.6	Tread, Front	b10	mm	940	940	940	940	950	940	940	950	940	940	940	940	950	
	3.7	Tread, Rear	b11	mm	865	865	865	865	865	865	865	865	170	170	170	170	170	
	Dimensions	4.1	Tilting Angle	α / β	Forward/Backward	degree	6/10	6/10	6/10	6/10	6/10	6/10	6/10	6/10	6/10	6/10	6/10	
4.2		Mast Height, Lowered	h1	2-stage Mast	mm	1995	1995	1995	1995	2110	1995	1995	2110	1995	1995	2110		
4.3		Std. Free Lift	h2	2-stage Std. Mast, from Ground	mm	135	140	140	140	150	140	140	150	135	135	140	150	
4.4		Std. Lift Height	h3	2-stage Std. Mast, from Ground	mm	3000	3000	3000	3000	3000	3000	3000	3000	3000	3000	3000	3000	
4.5		Mast Height, Extended	h4	2-stage Std. Mast	mm	3955	3955	3955	3955	3970	3955	3955	3970	3955	3955	3955	3970	
4.7		Height, Overhead Guard	h6		mm	2070	2070	2070	2070	2070	2070	2070	2070	2070	2070	2070	2070	
4.19		Length, with Std. Forks	l1		mm	2825	2980	2980	3015	3100	3115	3115	3170	2560	2560	2855	2920	3035
4.20		Length, to Fork Face	l2		mm	2055	2060	2060	2095	2180	2195	2195	2250	1790	1790	1935	2000	2115
4.21		Width, at Tyre	b1	Single	mm	1110	1110	1110	1110	1160	1110	1110	1160	1110	1110	1110	1160	
4.22		Forks	s/e/l	Thickness / Width / Length	mm	31x100x770	35x100x920	35x100x920	35x100x920	36x122x920	35x100x920	35x100x920	36x122x920	31x100x770	31x100x770	35x100x920	35x100x920	36x122x920
4.23		Fork Carriage Class	ISO 2328, Type A/B/no			Class 2, Type A	Class 2, Type A	Class 2, Type A	Class 2, Type A	Class 2, Type A	Class 2, Type A	Class 2, Type A	Class 2, Type A	Class 2, Type A	Class 2, Type A	Class 2, Type A	Class 2, Type A	
4.24		Width, Fork Carriage	b3		mm	970	970	970	970	970	970	970	970	970	970	970	970	
4.31		Ground Clearance	m1	Under Mast	mm	95	95	95	95	95	95	95	95	95	95	95	95	
4.32			m2	at Center of Wheelbase	mm	125	125	125	125	125	125	125	125	125	125	125	125	
4.33		Right Angle Stacking Aisle	Ast	with L1000 x W1200 pallet	mm	3150	3155	3155	3190	3275	3335	3335	3395	2790	2790	2935	2995	3115
4.34	Ast		with L1200 x W800 pallet	mm	3350	3355	3355	3390	3475	3535	3535	3595	2990	2990	3135	3195	3315	
4.35	Turning Radius	Wa		mm	1750	1750	1750	1785	1850	1930	1930	1970	1390	1390	1530	1590	1690	
Performance	5.1	Travel Speed (FWD)	Loaded / Unloaded	km/h	15.0/17.0	15.0/17.0	15.0/17.0	15.0/17.0	14.0/16.0	15.0/17.0	15.0/17.0	14.0/16.0	15.0/17.0	15.0/17.0	15.0/17.0	15.0/17.0	14.0/16.0	
	5.2	Lifting Speed	Loaded / Unloaded	mm/s	340/600	340/600	340/600	320/600	280/500	340/600	320/600	280/500	340/600	340/600	340/600	320/600	280/500	
	5.3	Lowering Speed	Loaded / Unloaded	mm/s	450/550	450/550	450/550	450/550	370/440	450/550	450/550	370/440	450/550	450/550	450/550	450/550	370/440	
	5.6	Max. Drawbar Pull	Loaded, 3min. rating	N	9560	9560	9560	9560	9045	9560	9560	9045	9560	9560	9560	9560	9045	
	5.8	Max. Gradeability	Loaded, 3min. rating/1.5/h	%	19	19	19	16	14	16	16	14	19	19	19	16	14	
	5.10	Service Brake	Operation/Control	Foot/Hydraulic	Foot/Hydraulic	Foot/Hydraulic	Foot/Hydraulic	Foot/Hydraulic	Foot/Hydraulic	Foot/Hydraulic	Foot/Hydraulic	Foot/Hydraulic	Foot/Hydraulic	Foot/Hydraulic	Foot/Hydraulic	Foot/Hydraulic	Foot/Hydraulic	
	5.10.1	Parking Brake	Operation/Control	Hand/Mechanical	Hand/Mechanical	Hand/Mechanical	Hand/Mechanical	Hand/Mechanical	Hand/Mechanical	Hand/Mechanical	Hand/Mechanical	Hand/Mechanical	Hand/Mechanical	Hand/Mechanical	Hand/Mechanical	Hand/Mechanical	Hand/Mechanical	
	5.10.2	Steering	Type	FHPS	FHPS	FHPS	FHPS	FHPS	FHPS	FHPS	FHPS	FHPS	FHPS	FHPS	FHPS	FHPS	FHPS	
	Drive	6.1	Drive Motor(AC)	60min.rating	kW	4.5x2	4.5x2	4.5x2	4.5x2	4.5x2	4.5x2	4.5x2	4.5x2	4.5x2	4.5x2	4.5x2	4.5x2	
		6.2	Pump Motor(AC)	5 min.rating	kW	9.0	9.0	9.0	9.0	9.0	9.0	9.0	9.0	9.0	9.0	9.0	9.0	
6.4		Battery Voltage		V	48	48	48	48	48	48	48	48	48	48	48	48		
6.4.1		Battery Capacity,Min		Ah/5hr	330	330	402	402	468	645	645	645	280	280	402	402	468	
6.4.2		Battery Capacity,Max		Ah/5hr	565	565	565	565	565	725	725	725	370	370	565	565	565	
6.5		Battery Weight	Min.Capacity Battery,See line 6.4.1	kg	610	610	720	720	760	1000	1000	1000	515	515	720	720	760	
Others	8.1	Drive Motor Control			Transistor	Transistor	Transistor	Transistor	Transistor	Transistor	Transistor	Transistor	Transistor	Transistor	Transistor	Transistor		
	8.2	Relief Pressure Attachment		bar	176	176	176	176	176	176	176	176	176	176	176	176		
	8.2.1	Hydraulic Oil Capacity		Ltr	23	23	23	23	23	23	23	23	23	23	23	23		

Dimensions/AE50 Series

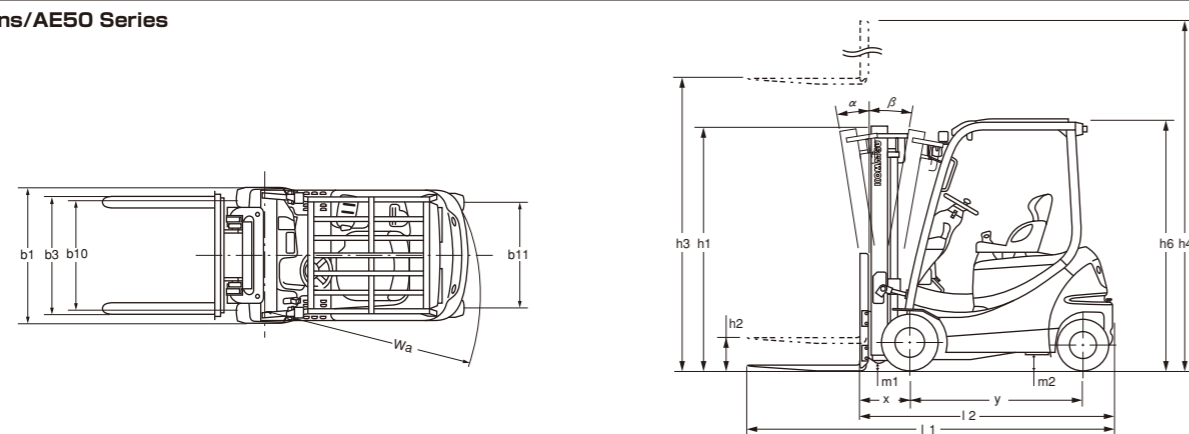

Dimensions/AM50 Series

